

Appendix D
Mare Island
Dredged Material Disposal Facility
Hydraulic Unloader Fish Exclusion Screen
Design Guidelines

**MARE ISLAND
DREDGED MATERIAL DISPOSAL FACILITY
HYDRAULIC UNLOADER FISH EXCLUSION SCREEN
DESIGN GUIDELINES**

1.1 Background

Hydraulic placement of dredged material requires dilution of the material with water to create a slurry of about 80 percent make-up water and 20 percent dredged material. The placement of 8,000 cy (assumed daily rate) into the Mare Island dredged material placement facility (DMDF) results in about 7 to 8 mgd of makeup water being taken from the Carquinez Strait. Hydraulic unloaders mix water with the dredged material, and then pump the material via a pipeline to the placement site. In the process of taking makeup water from the Bay, there is the possibility that salmonid fry and other similarly sized fish may be entrained in the pumps. Additionally, zooplankton will become entrained in the pumps, which are prey species for fish. To reduce this impact to a less than significant level, the operator of the hydraulic off-loader (typically the dredging contractor) will be provided the means and methods necessary to prevent fish and zooplankton entrainment.

Since every hydraulic unloader is configured differently, there is vast array of mechanisms that may be used to screen the pump intakes. The intention of this document is not to design one particular screening mechanism, but rather to provide the contractor with the criteria they will need to design a screening mechanism that is best suited to their own hydraulic unloader. The contractor, in turn, will be required to gain approval and permits from the appropriate resource agencies, including the California Department of Fish and Game (CDFG), National Marine Fisheries Service (NOAA Fisheries) and the U.S. Fish and Wildlife Service (USFWS).

1.2 Design Specifications

The design specifications are based on the requirements contained in the following references.

1. "Fish Screening Criteria for Anadromous Salmonids, National Marine Fisheries Service, Southwest Region, January, 1997"
2. "Exhibit D, CA Department of Fish and Game Fish Screening Criteria, June 19, 2000"
3. ADDENDUM, Juvenile Fish Screen Criteria for Pump Intakes, developed by National Marine Fisheries Service, Environmental & Technical Services Division, Portland, Oregon, May 9, 1996.

Additional design specifications were recommended by NOAA Fisheries (Thomas pers. comm.). The approach velocity criterion for the area is 0.8 fps for juvenile salmonids greater than 60 mm in length. The screen area required is $(26.5/0.8) \times 4 = 133$ sq ft. The approach velocity could be achieved with a single cylinder 7 ft in diameter and about 6 ft long. Another option would be to have a Tee screen, which is two cylinders on either end of a Tee shape, and each cylinder could be approximately 5 ft in diameter and 4 feet long. With either cylindrical option, preferably the long axis of the screens should be parallel to the current to give an approach velocity of 0.2 fps, which is the criterion for delta smelt on self-cleaned screens.

In general, the intake screening mechanism will be located in at least 10 meters of water, and will be positioned between the water column interval 4 meters below the water surface and 4 meters above the Bay bottom, thereby avoiding the most active zones used by the fish and their prey species (zooplankton and phytoplankton) in the area. Since 1995, the California Department of Fish and Game (CDFG) has conducted a series of annual surveys throughout the Delta and San Pablo bay to assess the timing, distribution, and abundance of delta smelt larvae and their food (specifically zooplankton). As part of their 20 mm survey, zooplankton are collected from the entire water column, which precludes the ability to evaluate the distribution of prey species in the water column by depth. However, CDFG also collects

physical parameters as part of the tow data, including water transparency. The depth of light penetration (as measured by Secchi disk) extends from a few inches to a few feet below the surface from early spring to late summer in the vicinity of the proposed project intake. This suggests that the depth of the intake structure will avoid the highly productive photic zone that attracts phytoplankton, primary grazers, and their planktonic predators. In addition, the distance of the structure from the bottom will avoid the productive benthic layer where many infaunal, epifaunal, and demersal species reside.

The resource agencies provide options for two types of screening mechanisms: self-cleaning screens, and screens that are not self-cleaning. Specifications for both options are included below.

1.2.1 Self-Cleaning Screens

The resource agencies require that the water velocity vector perpendicular to the screen face (approach velocity) not exceed 0.2 foot per second for delta smelt. Additionally, the agencies require that the screen face material meet the following criteria.

1. Perforated plate: screen openings shall not exceed 3/32 inches (2.38 mm), measured in diameter.
2. Profile bar: screen openings shall not exceed 0.0689 inches (1.75 mm) in width.
3. Woven wire: screen openings shall not exceed 3/32 inches (2.38 mm), in the narrow direction. (e.g. 6-14 mesh).
4. Screen material shall provide a minimum of 27 percent open area.

Additional design criteria are contained in the three documents referenced above.

In order to meet the above described resource agency requirements when using self-cleaning screens, the contractor will be required to utilize brushed cylinder screens manufactured by Intake Screens, Inc. (ISI) of Sacramento, California, or equivalent. The brushed cylinder screen shall be installed such that the long axis of the cylinders is parallel to the flood and ebb currents.



Figure 1 – Example of Intake Screens, Inc. Brushed Cylinder Screen

1.2.2 Screens That Are Not Self-Cleaning:

The resource agencies require that the approach velocity for non self-cleaning screens be one-fourth that of the self-cleaning screens. This results in an approach velocity not cannot exceed 0.0825 foot per second. One possible option for achieving this velocity is to surround the intake by a square or rectangular cage (see Figure 2). The two sides of the cage that are perpendicular to the tidal flows shall be solid. The remaining four sides must have a total area equal to the following equation (excluding area of structural components).

$$Q \text{ (intake flow)}/0.0825 \text{ fps}$$

Additional requirements include the following.

1. Fish screen panels shall be of all welded construction utilizing continuously controlled TIG (fusion) welding to ensure slot accuracy. The screen surface shall be a profile wire shape with inwardly widening openings to minimize the likelihood of debris entrapment. The screen slot openings shall be continuous over the entire width of each panel. Screens shall be continuous unspliced pieces except where specifically allowed. Wrapped or looped wire construction is not acceptable. Screens fabricated in cylindrical form and rolled flat are not acceptable. The fish screens shall be as manufactured by Norris Screen, 403 South Wickham Avenue, Princeton, WV 24740, or approved equal.
2. The profile wires shall be spaced to provide 0.0690 in. (1.75 mm) net openings between the wires with a minimum open area of 27 percent.
3. The upstream face of the fish screens shall be finished flat, smooth with no nicks, burrs, dents or sharp edges.
4. The fish screens shall have a maximum through-slot velocity not to exceed 0.33 feet per second. Assuming 90 percent of clean screen availability, the pressure drop through the screen shall not exceed 0.1 psi.
5. Unless otherwise specified, the fish screens shall be constructed of ASTM A276, Type 316L for seawater applications.
6. The intake pipe must be centrally located inside the cage to prevent approach velocity “hot spots.”
7. The screen must be periodically cleaned before the approach velocity exceeds 0.33 feet per second. The cage must be able to be raised above the water surface so that it can be visually inspected.

1.2.2.1 Example Application of Screens that are Not Self-Cleaning

See Figure 2 for a diagram of an example screen that is not self-cleaning.

Given: Make-up water needed at a flow of $Q = 26.5$ CFS.

Therefore, the total screen area, not including structural components, is 321 square feet ($26.5 \text{ CFS}/0.0825$ foot per second).

Given four sides of a cage, this yields 80.3 square feet per side. Assuming square sides, the dimensions are 9 feet by 9 feet.

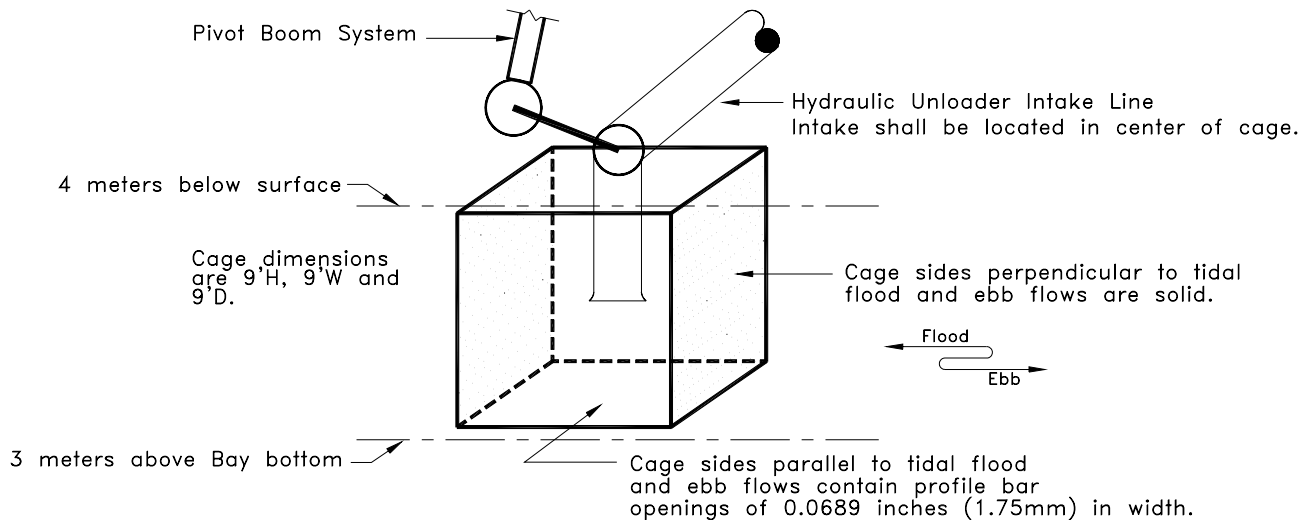

FIGURE 2 – EXAMPLE APPLICATION OF A TYPICAL NON SELF-CLEANING FISH SCREEN CAGE

Not To Scale

1.3 Contractor Submittals For All Screening Options

The following submittals will be required of the contractor installing the screening mechanism:

1.3.1 Shop Drawings

1. Manufacturer's catalog information, descriptive literature, specifications, dimensional layouts and identification of materials of construction.
2. Detailed structural and/or mechanical drawings showing equipment fabrications and interface with other items. Include dimensions, sizes, weights and locations of connections to other work and associated equipment.
3. Design calculations and service conditions.
4. Functional test procedures.

1.3.2 Quality Control Submittals

1. Manufacturer's Certificate of Compliance for materials and factory tests.
2. Special shipping, storage, protection and handling instructions.
3. Manufacturer's installation instructions.

4. Operation and maintenance manuals.

1.4 Literature Cited

Bari, Russ, Intake Screens, Inc. January 2002. Personal communication.

California Department of Fish and Game. 2000. *Exhibit D, Fish Screening Criteria*.

Heise, George, California Department of Fish and Game. January 2002. Personal communication.

National Marine Fisheries Service, Environmental & Technical Services Division. 1996. *ADDENDUM, Juvenile Fish Screen Criteria for Pump Intakes*. Portland, Oregon.

National Marine Fisheries Service, Southwest Region. 1997. *Fish Screening Criteria for Anadromous Salmonids*.

Nordlund, Bryan, P.E. 1996. *Designing Fish Screens for Fish Protection at Water Diversions*. Prepared for the National Marine Fisheries Service, Portland, Oregon.

Norris Screen and Manufacturing, Inc. Fish Screen Sample Specifications.

Strong, Jim. Aquadyne, Inc. January 2002. *Personal communication*.

Thomas, Steve. NOAA Fisheries. March 2005. *Personal communication*.

Toler, Kevin. Norris Screen and Manufacturing, Inc. January 2002. *Personal communication*.

Wantac, Rick. National Marine Fisheries Service. January 2002. *Personal communication*.